

SPT299



HENAN SPT MACHINERY
EQUIPMENT CO., LTD.

Mini Crawler Crane (Spider Crane)

SPT Brand Spider Crane - Benchmarking
the World's Highest Standard

Intelligent, safe and more durable

SPT299



Max lifting height 9.5m

Working radius 8.83m

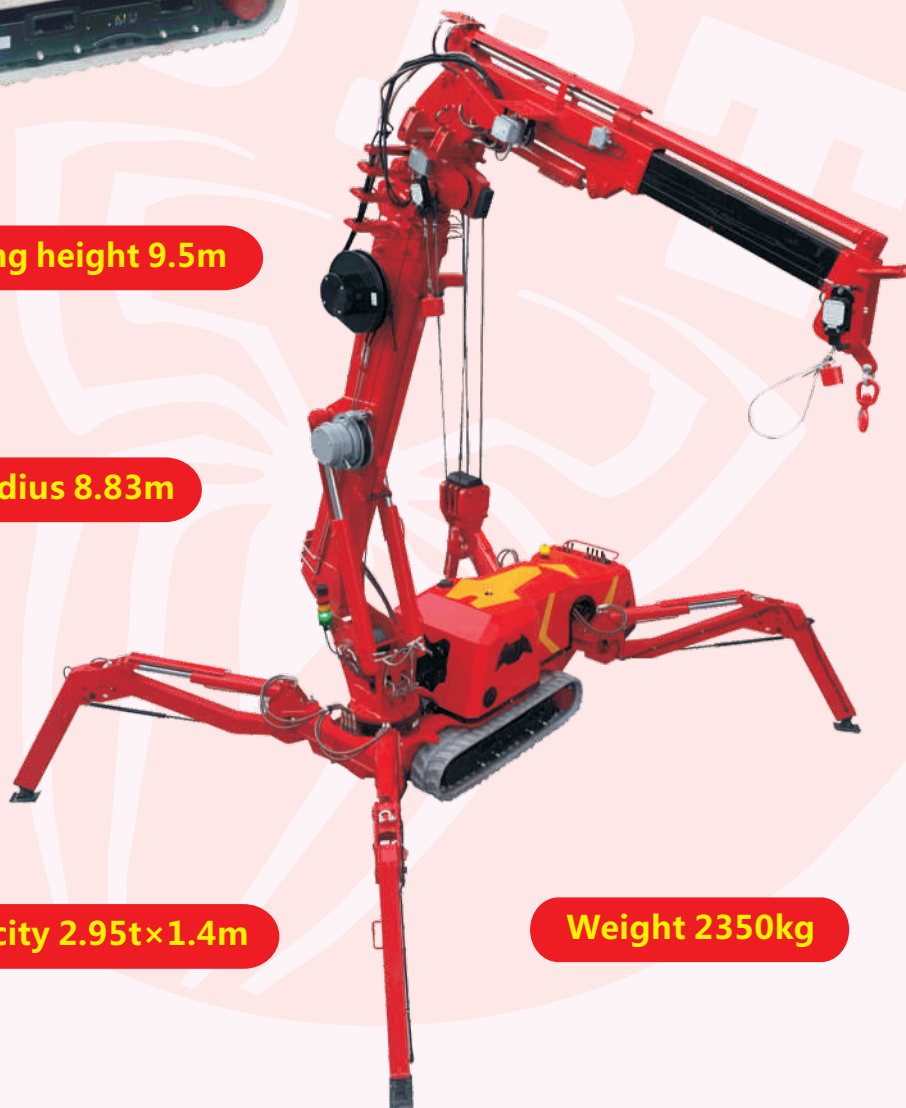

Capacity 2.95t×1.4m

Weight 2350kg

SPT299



Working Range Diagram Without Fly Jib

SPT299 Working Range Diagram

299-11
Weight: T

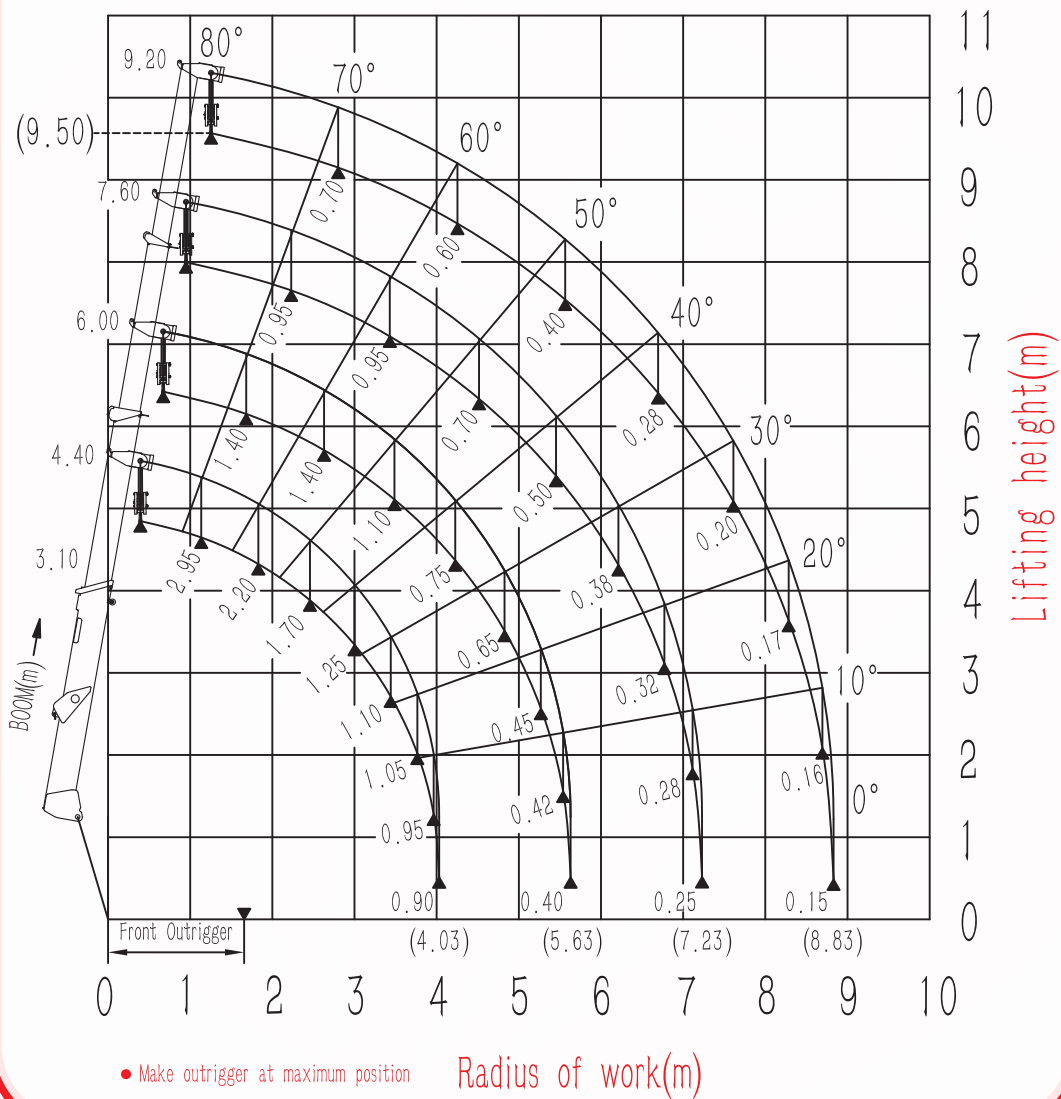

SPT299



Outrigger Footprints

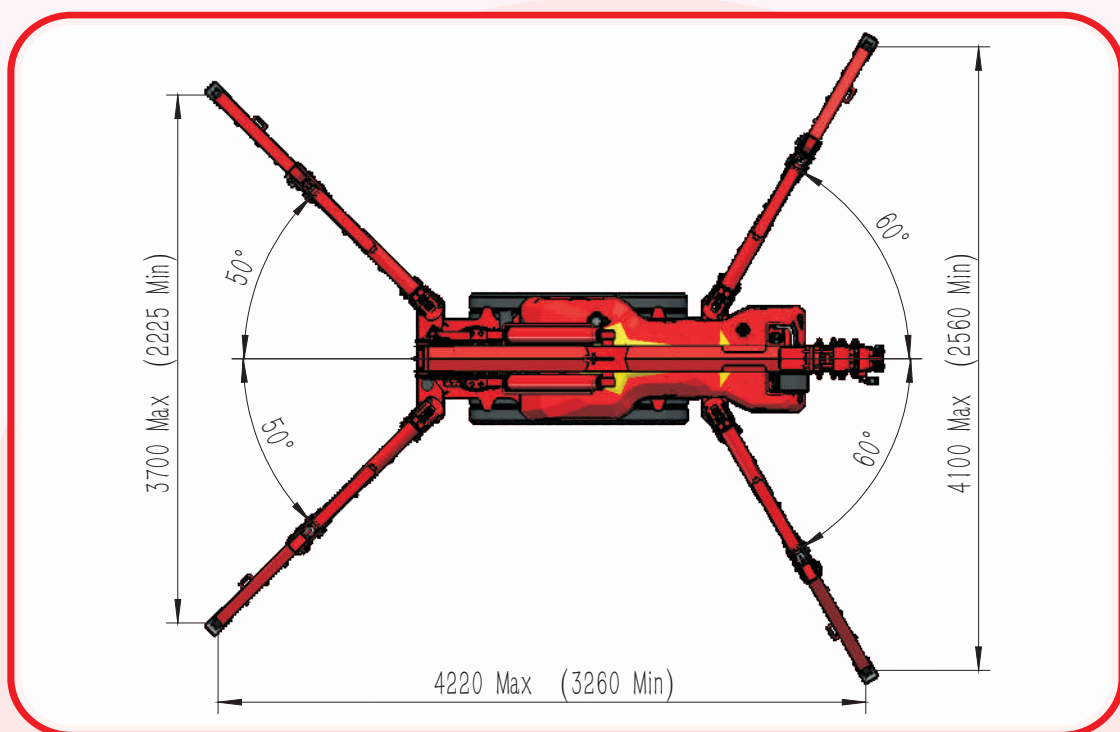

Dimensions

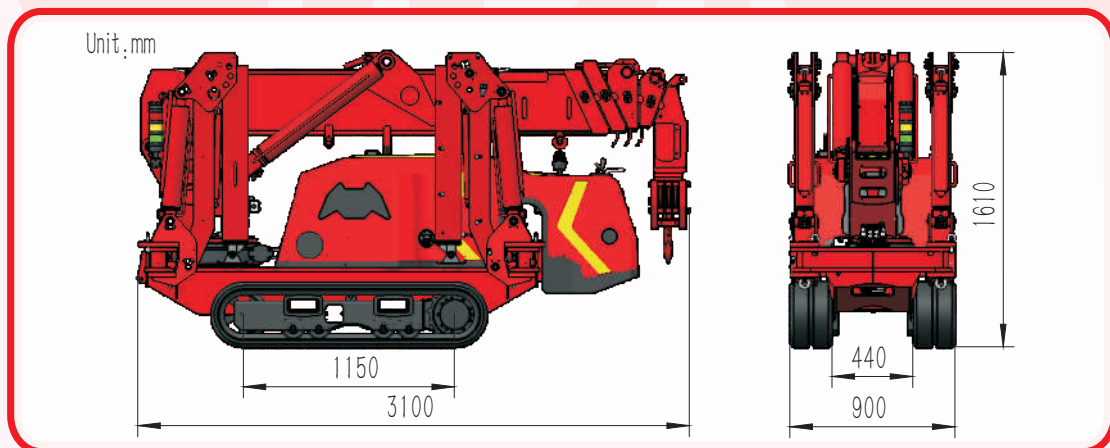

SPT299



Specifications

Model	SPT299	
Capacity	2.95t × 1.4m	
Working radius	8.83m × 0.15t	
Ground lifting height	9.50m × 0.70t	
Underground lifting height	10m-4 fall 20m-2 fall 40m-1 fall	
Winch device	Hook speed	0-8m/min (4 fall)
	Rope type	Φ8mm × 45m
Telescopic system	Boom form	5 section boom, hexagonal box construction
	Boom length/Time	3.1m-9.2m/20sec
Up and downs	Boom angle/Time	0-80° /13sec
Slew system	Slew angle/Speed	0-360° (continuous) /60sec
Outrigger	Outrigger active form	Manual + Hydraulic
	Maximum extended dimensions (mm)	4220 (Length) X3700 (Front) X4100 (Back)
Traction system	Walking way	Hydraulic motor drive、 2 speed
	Walking speed	0-2.5km/h
	Grade ability	20° (36%)
	Ground length × width	1150mm × 230 mm
	Ground pressure	42kpa (0.43kgf/cm ²)
Electric motor	Voltage	AC380V (Optional)
	Power/Speed	4kw/1440 min-1
	Sound level	Rated speed ≤75dB (A) (1m)
Diesel engine	Model	3TNV74F (YANMAR)
	Type/Displacement	3 Cylinder water cooled/0.993L
	Rated output	11.2kw/2400 min-1
	Starting method	Electric
	Operating temperature	-5° C~40° C
	Fuel/Volume	Diesel/18L
	Battery capacity	12v 45AH
	Specific fuel consumption	284g/kW-h
	Sound Level	Rated speed ≤82.5dB (A) (1m)
Operate system	Applied regulation/Altitude	EPA-Tier4, EC stage V/1200m
	Type of operation	Wireless remote control and manual operation
Dimension	Operating characteristic	Full proportional control
	Length × Width × Height	3100mm × 900mm × 1610mm
Weight	(Without optional equipment)	2350kg
Standard configuration	Diesel engine, Electric motor, Radio remote control, Searcher hook, Black rubber track, Intelligent display screen, Moment limiter, Over hoist alarm and automatic stop device, Three-winding alarm and automatic stop device, Automatic hook stow, Outrigger position detector device, Outrigger off the ground alarm and automatic stop device, Slings rope detachment protector, EMO switch, Three color lamp, Remote control lamp, Voice prompt, Walking/Outrigger/Boom three-mode interlock system, Data records	
Optional configuration	Glass suction, White rubber track, Manual fly jib, Hydraulic fly jib, Single-man basket, Outrigger pads	

SPT299



■ Total rated load Outriggers at Maximum position(4fall)

3.10/4.40boom		6.00boom		7.60boom		9.20boom	
Working radius (m)	Total ratedload (t)	Working radius (m)	Total ratedload (t)	Working radius (m)	Total ratedload (t)	Working radius (m)	Total ratedload (t)
< 1.40	2.95	< 2.80	1.40	< 3.50	0.95	< 4.00	0.70
1.50	2.80	3.00	1.30	4.00	0.80	4.50	0.60
2.00	2.10	3.50	1.10	4.50	0.70	5.00	0.50
2.50	1.70	4.00	0.85	5.00	0.55	5.50	0.40
3.00	1.30	4.50	0.70	5.50	0.50	6.00	0.35
3.50	1.10	5.00	0.55	6.00	0.40	6.50	0.30
4.03	0.90	5.63	0.40	6.50	0.35	7.00	0.25
				7.23	0.25	7.50	0.20
						8.00	0.20
						8.83	0.15