

S7 Sky Series

BRING YOU ENDLESS
OPERATIONAL FUN!



SPT SAFE SPIDER CRANE
PROTECTING CONSTRUCTION
PROTECTING PEOPLE



**HENAN SPT
MACHINERY EQUIPMENT CO.,LTD.**



*SPT SAFE SPIDER CRANE
PROTECTING CONSTRUCTION
PROTECTING PEOPLE*

S7 Advantages:

1. Perfect dual operation ways, supporting manual & remote control operations, avoiding operational anxiety;
2. Dual powers, supporting diesel engine and electric motor(single-phase, 220V);
3. Dual display screen, both the crane operation console and remote control contain a color information display screen;
4. Extendable tracks, the minimum width of the entire crane is 770mm, with high passability;
5. The maximum lifting height exceeds 17 meters and supports multiple synchronized actions;
6. Can be transported with a trailer 3500kg;
7. Two-year global warranty.



S7 Sky Series



SPT SAFE SPIDER CRANE
PROTECTING CONSTRUCTION
PROTECTING PEOPLE

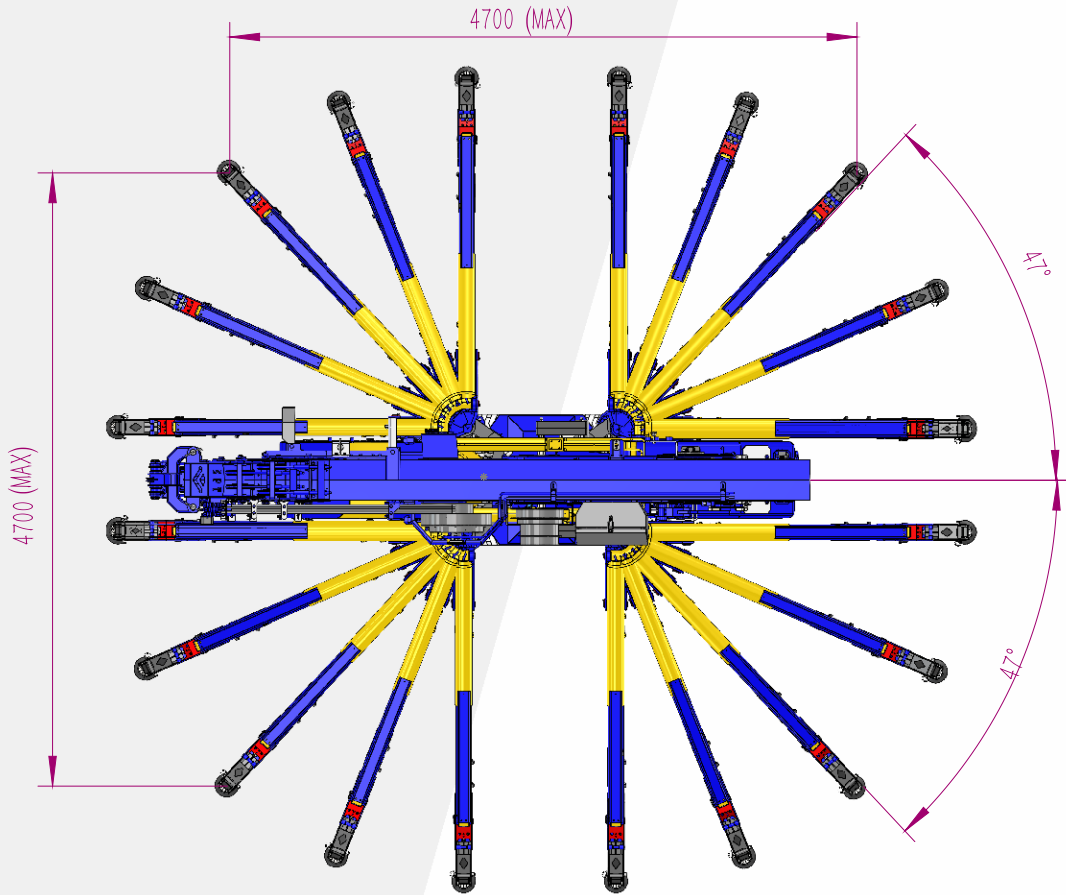

unit : mm

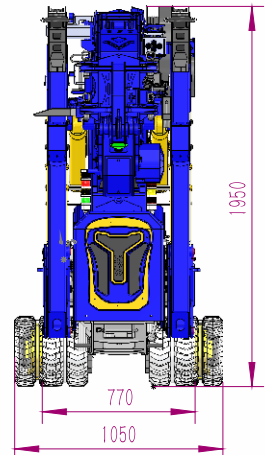
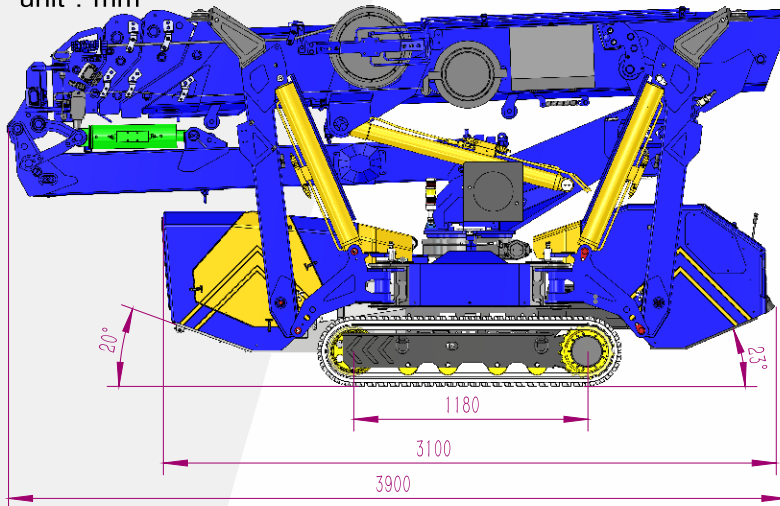

S7 Sky Series



Technical parameter table

Model	S7	
Capacity	2.98t×2.2m	
Workingradius	8.7m×0.5t / 14m×0.1t (with fly jib)	
Liftingheight	11.2m×1.6t / 17m×0.6t (with fly jib)	
Winchsystem	Hookspeed	0-7m/min (3 fall)
	Ropetype	Φ8mm×50m
Telescopicssystem	Boom form	4 section boom, hexagonal box construction
	Boom length/Time	3.2m-9.80m / 35sec
Up and downs	Boom angle/Time	0-80°/30sec
Slewing system	Slew angle/Speed	0-360° (continuous) /60sec
Outrigger	Outriggeractiveform	Manual+ Hydraulic
	Maximumextendeddimensions/mm	4700 (Length) ×4700 (Front) ×4700 (Back)
Tractionsystem	Walkingway	Hydraulicmotor drive, 2 speed
	Walkingspeed	0-2.0km/h
	Gradeability	20°(36%)
	Groundlength× width	1180mm×230 mm
	Groundpressure	51kPa (0.52 kgf / cm ²)
Electricmotor	Voltage	AC 220V—Single (Optional)
	Power/Speed	3KW/1440min-1
	Sound level	Ratedspeed≤75dB(A) (1m)
Dieselengine	Model	D902 (Kubota)
	Type/ Displacement	3 cylinderwatercooled/ 0.898L
	Ratedoutput	11.8kW/2300 min-1
	Startingmethod	Electric
	Operatingtemperature	-5°C~40°C
	Fuel/Volume	Diesel/16L
	Batterycapacity	12v 60AH
	Specificfuel consumption	274g/kW-h
	Sound Level	Ratedspeed≤81.5dB(A) (1m)
Appliedregulation/ Altitude	EC stageV , EPA-Tier4 / 1200	
Operatesystem	Type of operation(crane, walk),	Wirelessremotecontroland manual
	Operatingcharacteristic	Full proportionalcontroland linkagecontrol
Dimension	L×W×H (With fly jib)	3900mm×770mm×1950mm
Weight	With fly jib	2900kg

S7 Sky Series



S7 Load Chart With Fly Jib

Weight.t

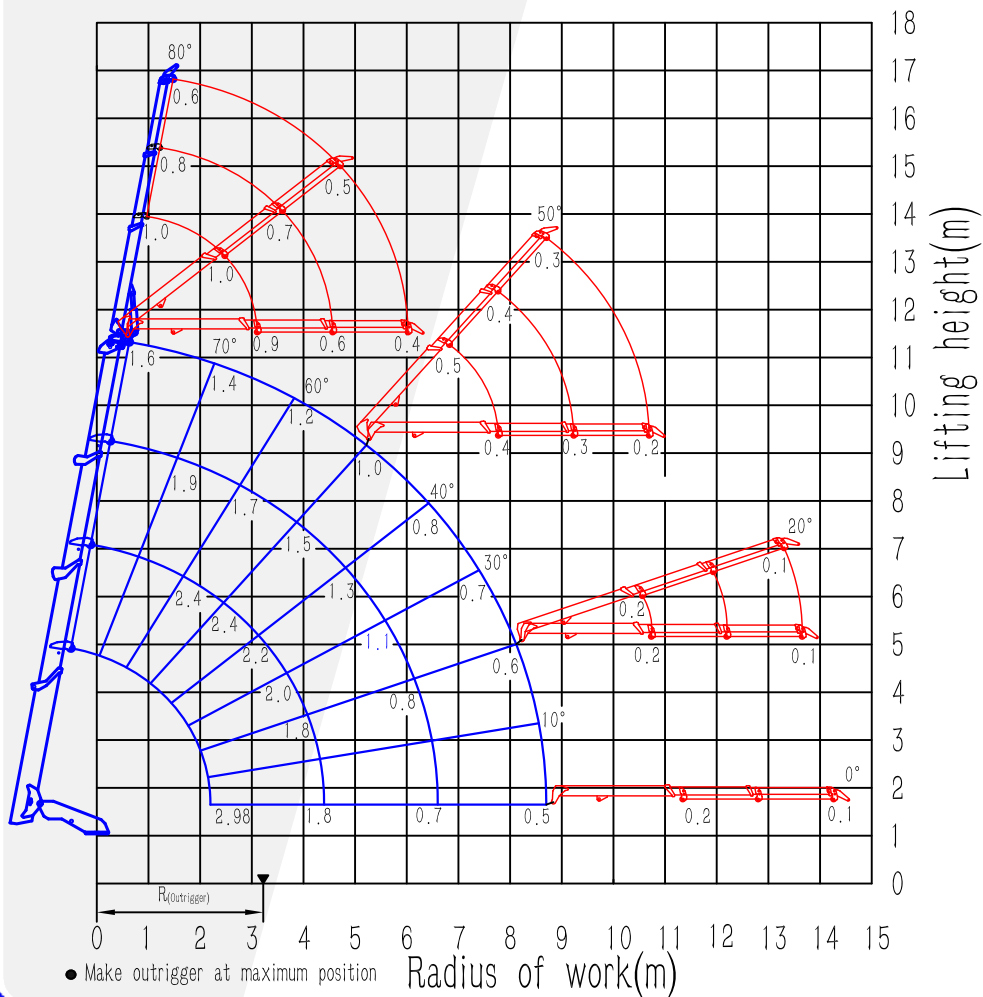

HENAN SPT MACHINERY EQUIPMENT CO.,LTD.

ADD.: NO.7 QINGLINAGSI AVENUE, LIANGYUAN DISTRICT, SHANGQIU, HENAN, CHINA

Email: info@sptcrane.com

Website: www.sptcrane.com